

## Vibration Screener SS.500

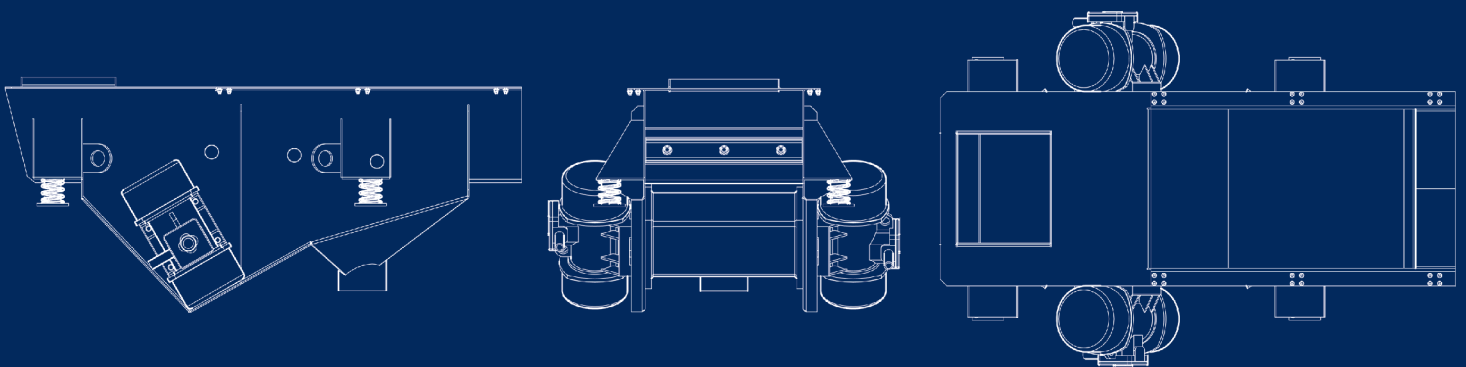

For pellet screening - dust content <5%;  
max. throughput of 500 - 3000 kg

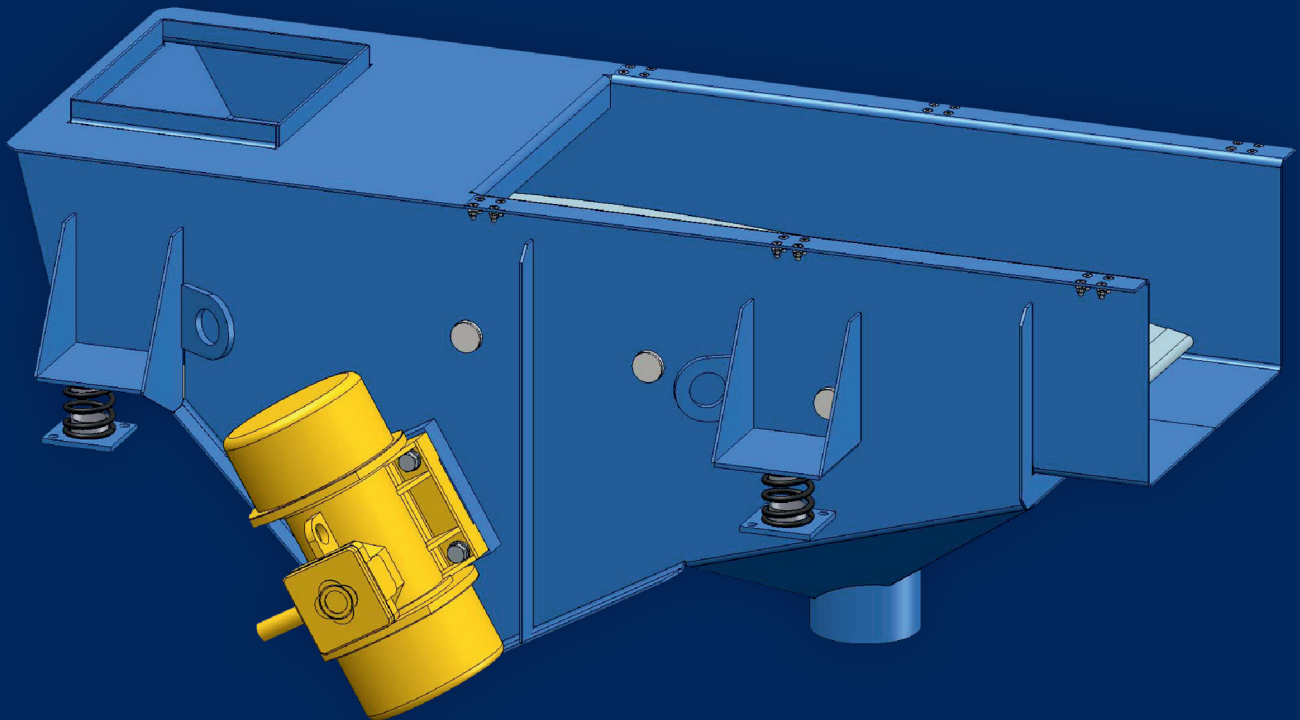
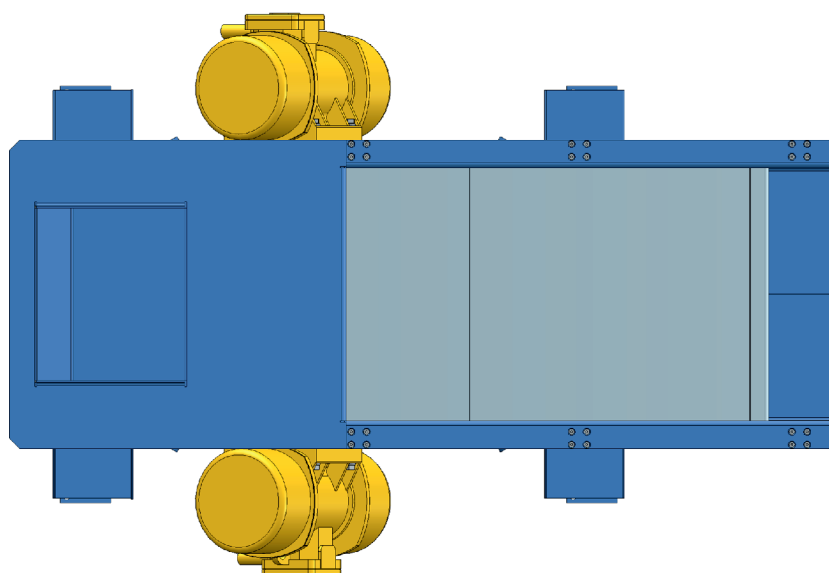
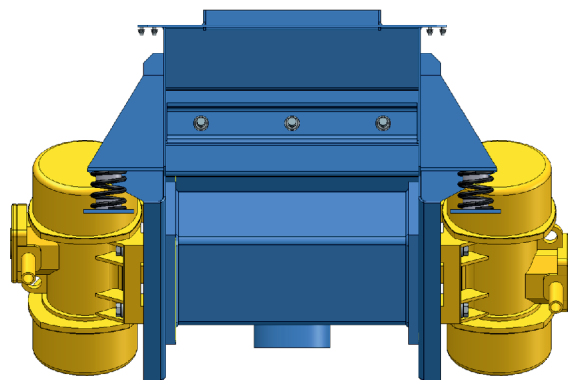
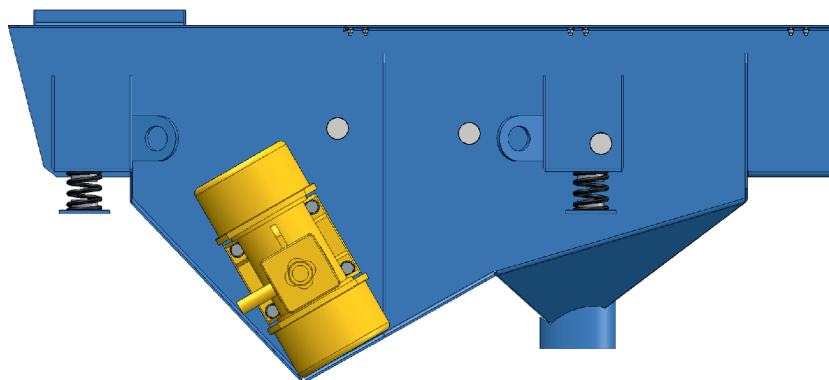
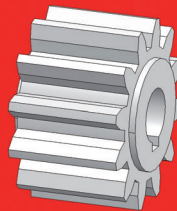

## Vibration Screener SS.500

Oscillating screen for dust separation.  
Our sieves are low-wear and product-safe  
and offer the following advantages:

- Robust construction for long life
- Low operating costs
- Low maintenance
- Proven technology

### Technical specifications

Type	SS.5 x 1600
Product	pellets
Bulk density	ca. 0,6 t/m <sup>3</sup>
Grain size	5 - 12mm
Dust content	< 5%
Sieving capacity	0,5 to 3 t/h
Material	S235JRG2
Surface	primed and varnished
RAL	by agreement

Including:

Screen: tensioning screen with mesh weave,  
MW = 5 mm  
Input: neck, 350x300 mm  
Output grain: over open front  
Output fine proportion: nozzles, D = 150 mm  
Drive: Unbalance-motor pair, type F 65-4-1.4  
400 V / 50 Hz; 2 x 0.40 kW;  
Protection class: IP 66  
Vibration isolation: compression springs  
Total weight: ca. 300 kg