

## Hammermühle HM.50

**N1:** Materialeinlauf  
**N2:** Materialauslauf

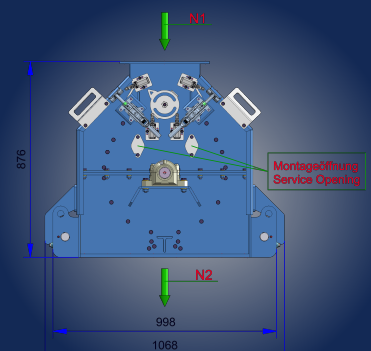
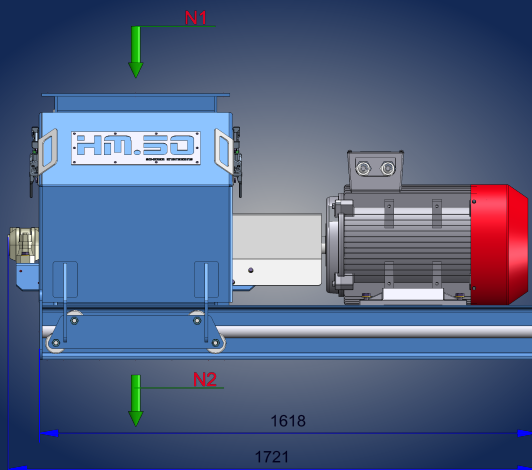
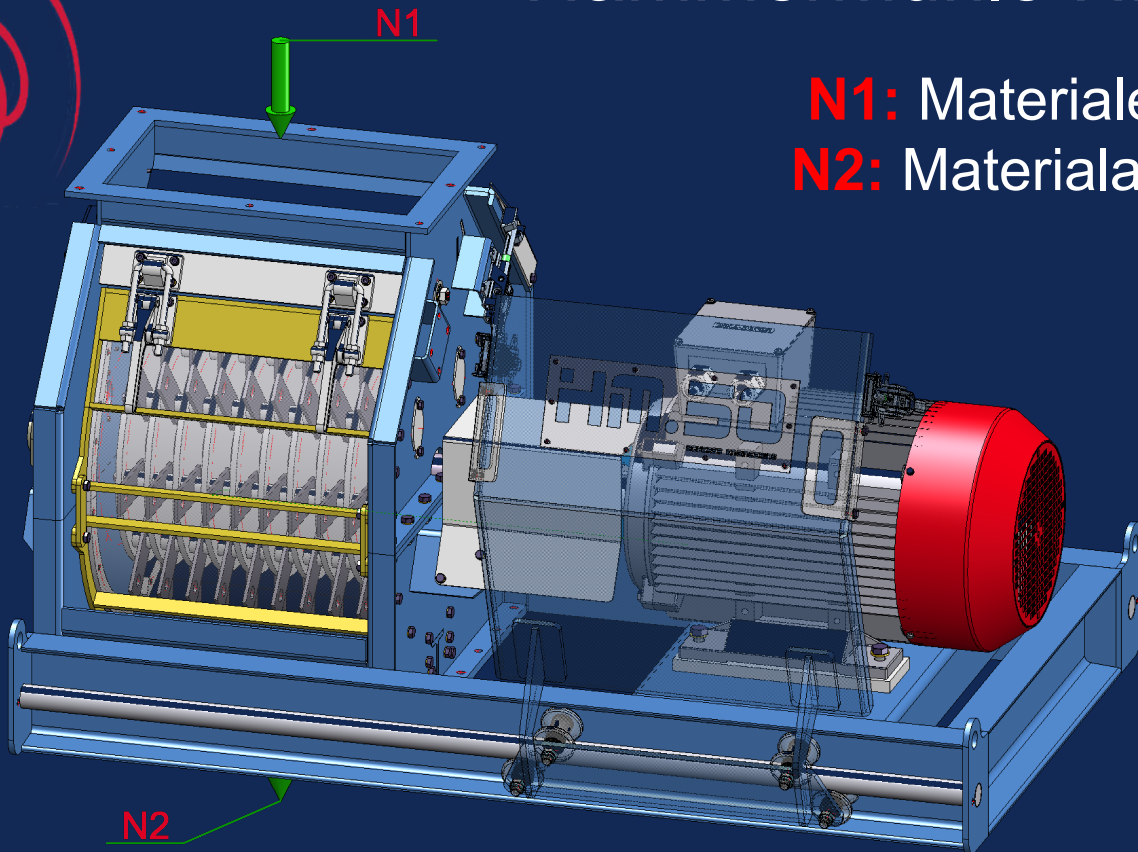

Zur Vermahlung von Biomasse mit  
einer Feuchtigkeit bis zu 15%

**Scherer Engineering GmbH**

Gewerbestr. 5 - 9560 Feldkirchen

[info@scherer-engineering.com](mailto:info@scherer-engineering.com)

[www.scherer-engineering.com](http://www.scherer-engineering.com)